

2020 Corvette: GM TechLink: All-New C8 - The 2020 Corvette Stingray Makes a Mid-Engine Move

All-New C8 – The 2020 Corvette Stingray Makes a Mid-Engine Move

March 31, 2020

The all-new eighth generation 2020 Chevrolet Corvette Stingray (C8) features a sleek, performance-focused design with a first-ever mid-engine configuration. (Fig. 1) The rear weight bias enables the capabilities of the new 6.2L V8 engine and 8-speed dual clutch transmission (DCT) to shine on the track. The result is the fastest and most powerful entry level Corvette ever produced with a 0-60 mph (0-97 km/h) time of under three seconds when equipped with the available Z51 Performance Package.



Fig. 1

In addition to its impressive performance, the new Corvette Stingray delivers supercar levels of technology, craftsmanship, and innovation, including use of GM's Next Generation Digital Vehicle Platform electrical architecture, which minimizes wiring while allowing for faster signal transmission between different vehicle systems and the higher resolution screens. The platform enables continuous vehicle improvements through over-the-air updates and enhanced cybersecurity measures.

Vehicle Access Points

The Corvette Stingray features large air intakes for engine cooling and aerodynamic performance. The sculpted design also incorporates hidden hood, door, and hatch/trunk releases.

Hood – The exterior hood release is located below the driver's headlamp in the front radiator opening. (Fig. 2)



Fig. 2

The hood can be released from inside the vehicle using the switch above the rear hatch release on the driver's door. There is also a manual release cable located to the left of the brake pedal below the instrument panel if the battery charge is low. (Fig. 3)

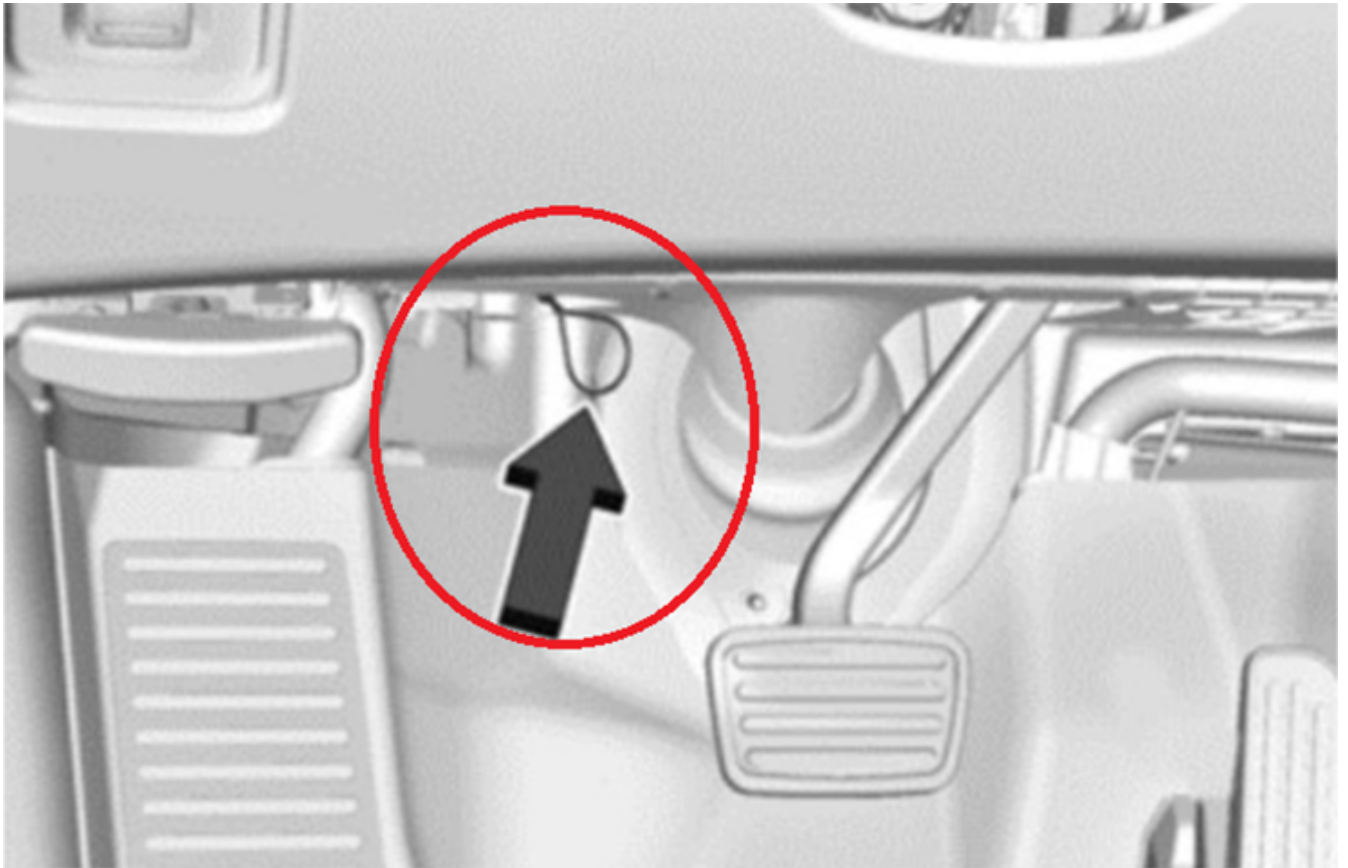

Fig. 3

The hood is not heavy enough to latch under its own weight when closing the panel. To close, firmly press down on the front edge of the hood until the latch clicks twice. The hood will remain open until the striker is pushed into the latch.

Doors – The door releases are located up under the door handle applique. (Fig. 4) The driver's door also has a keyed lock cylinder located under the left quarter panel cooling opening, just rear of the door opening. The key is

incorporated into the key fob. Manual door release levers are located on the driver and passenger floors, just like the previous generation Corvette.

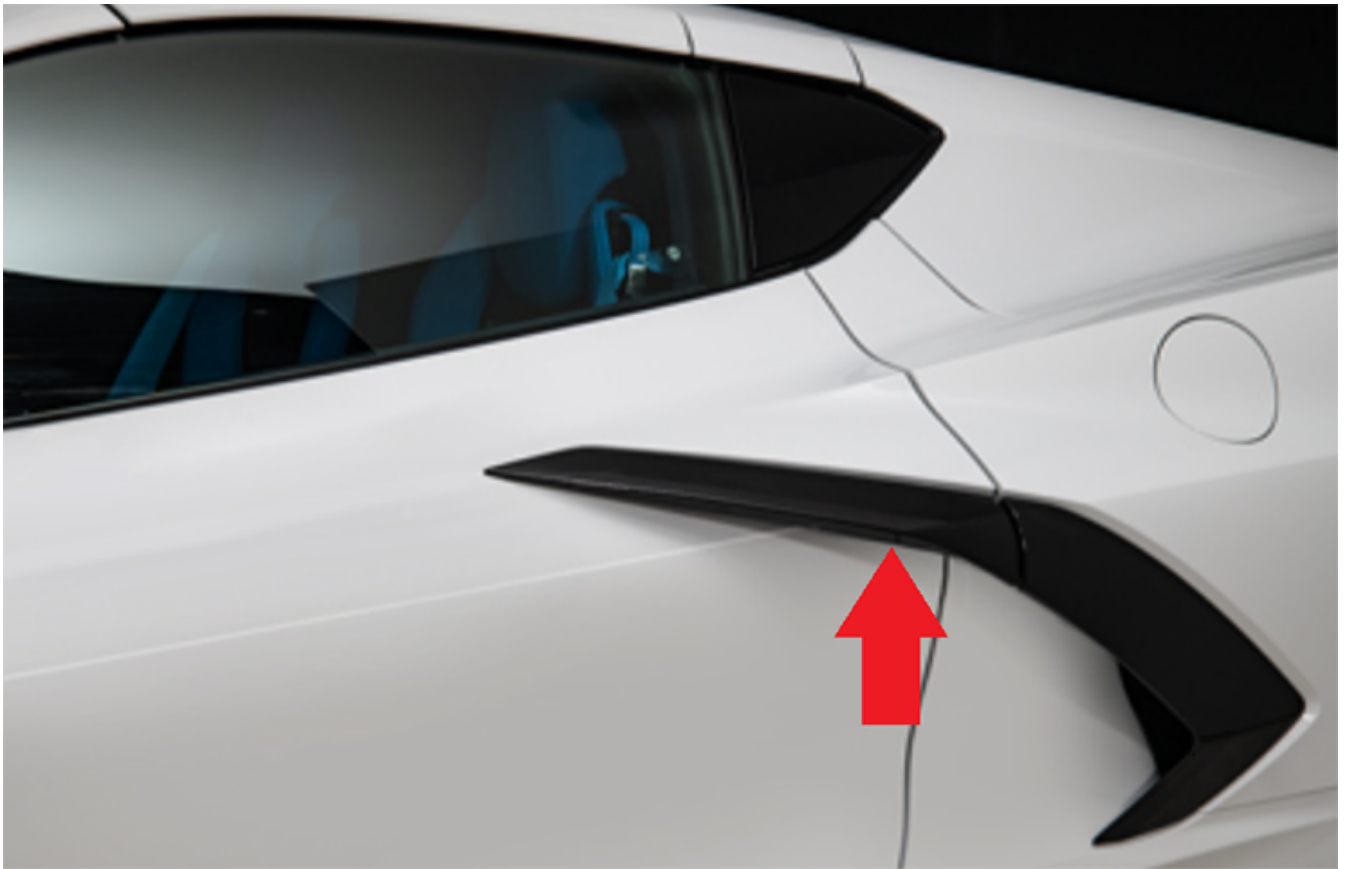

Fig. 4

Hatch/Trunk – The rear hatch/trunk can be released with either the interior or exterior switch. The interior switch is located in the map pocket area of the driver’s door panel. The exterior switch is located in the rear fascia above the license plate. (Fig. 5)



Fig. 5

To open the hatch/trunk manually, use the mechanical key in the key cylinder behind the license plate. The license plate must be removed for access.

Battery Location

The vehicle battery is located under the front windshield cowl panel. To access the battery cables or battery, remove the front compartment rear access cover that is held in place with two retainers and three clips. (Fig. 6)

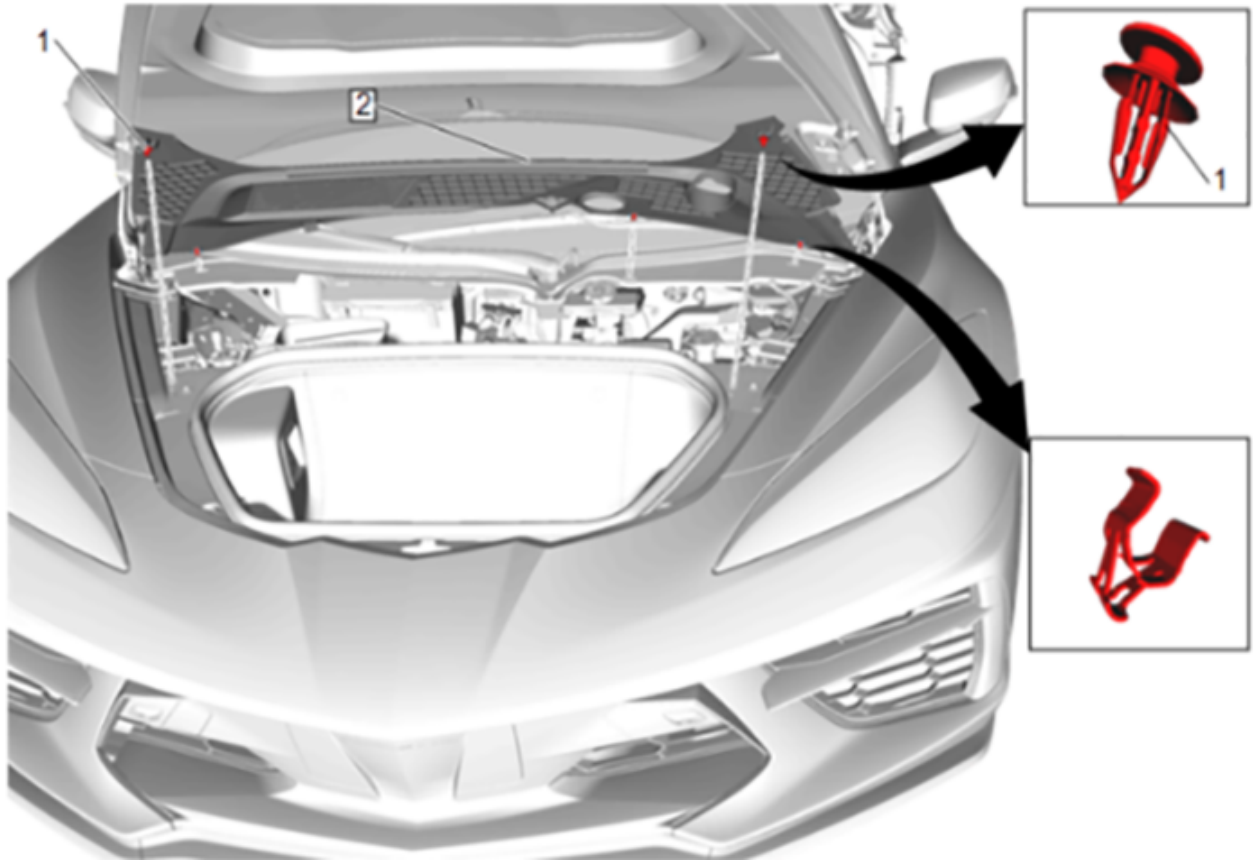

Fig. 6

Chassis

The new body structure of the 2020 Corvette Stingray is more than 10% stiffer than the previous generation. It features a strong, lightweight main structure with six high-pressure die cast aluminum parts that minimize the number of joints within the vehicle, making a stiffer structure that aids in handling and cornering. (Fig. 7) The Stingray also uses an industry-first carbon fiber curved rear bumper beam as well as front and rear trunk tubs and

dashboard molded from ultra-lightweight fiberglass and a proprietary resin. Along with the use of other fiberglass and carbon fiber variants, the design goal was to lower mass and reduce noise and vibration while enhancing performance.



Fig. 7

Structural repairs must be made by certified GM Collision Repair Network (CRN) or Cadillac Aluminum Repair Network (CARN) shops. Non-certified shops will not be permitted to receive the restricted structural part numbers

from a GM dealership. The majority of the structural frame components for the C8 Corvette will be put on parts restriction. GM dealerships with body shops can enroll at www.genuinegmparts.com/for-professionals/general-motors-collision-repair-network.

The rigid body structure provides a solid foundation for the front and rear frames and the four-wheel independent suspension system. (Fig. 8) The front suspension is a short/long arm design with double wishbone-type control arms. The upper control arm is forged aluminum and the lower control arm is cast aluminum. The rear suspension also uses a short/long arm design with double wishbone-type control arms, replacing the transverse composite springs. Magnetic Selective Ride Control 4.0 is available with the Z51 option package.

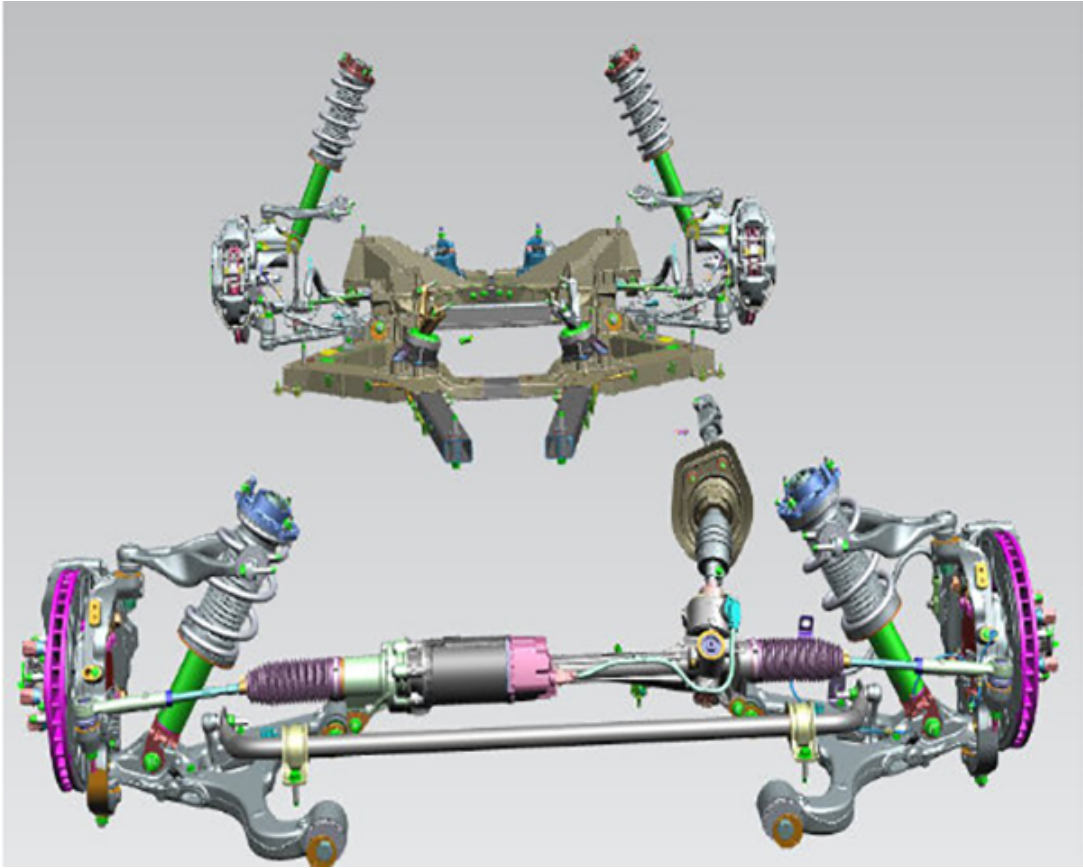

Fig. 8

Front Lift System

The E60 adjustable front lift system with memory is available to lift the front of the car when entering steep driveways or driving over road disturbances, such as speed bumps, to help reduce the potential for damage to the front spoiler. The two-position lift actuators in the front shocks can lift the front end by 1.4 in. (35 mm) in less than three seconds when the vehicle is moving less than 25 mph (40 km/h). (Fig. 9) The system lowers manually using a

switch or automatically when the vehicle reaches 24 mph (39 km/h). The button to activate the system is located in the front of the center console.

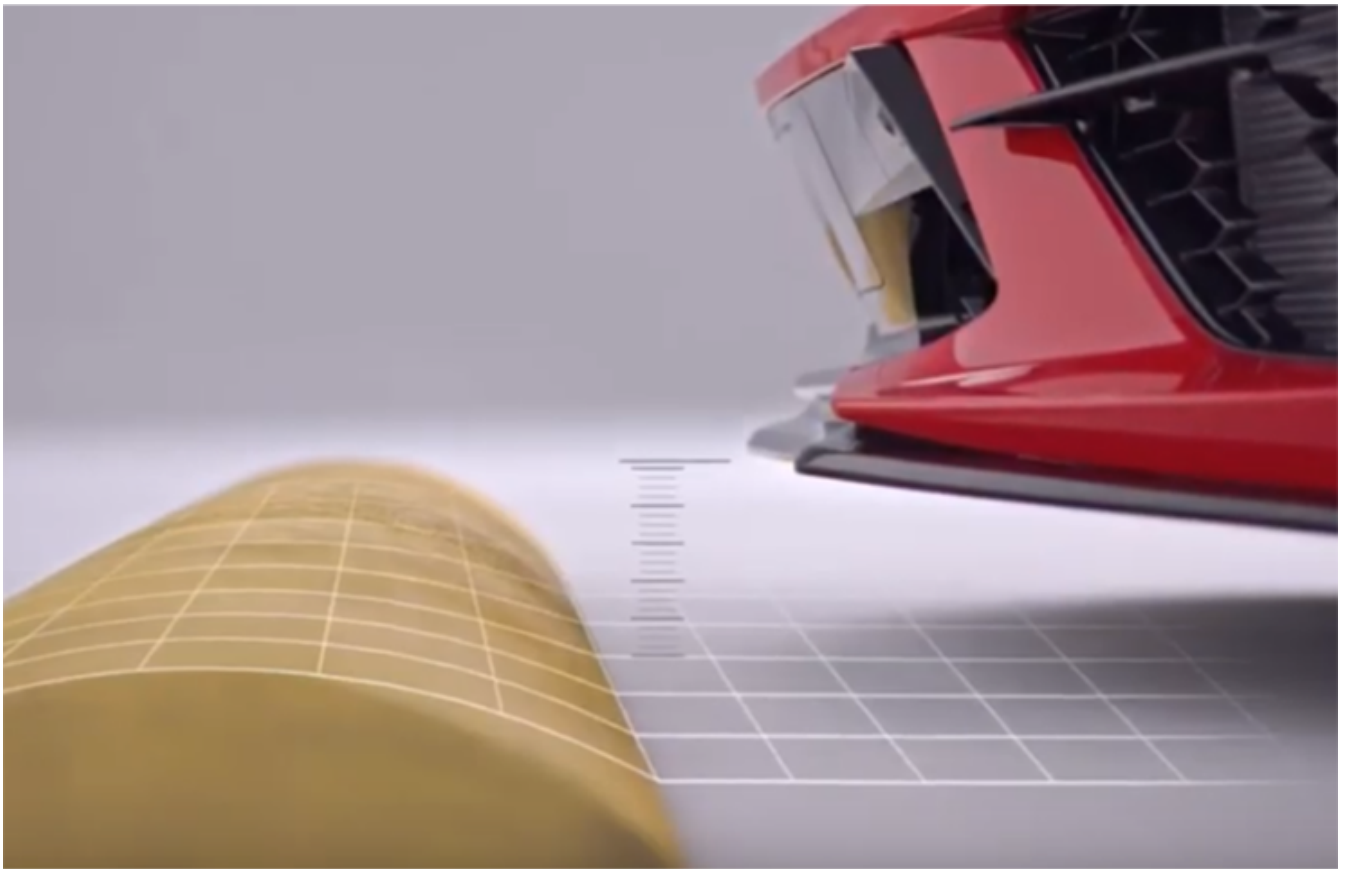

Fig. 9

The system also has a GPS-based auto lift feature that can store up to 1,000 unique locations. Locations are stored using the Driver Information Center (DIC) controls on the steering wheel.

Brakes

The 2020 Corvette Stingray features two brake options. RPO JL9 is the base brake system with all-aluminum four-piston calipers with 12.6 in. (321 mm) ventilated Ferritic Nitrocarburizing (FNC) rotors in the front and 13.3 in. (339 mm) ventilated FNC rotors in the rear.

The up-level RPO J55 brake system (Fig. 10), standard on all Z51 models, uses ventilated, non-FNC 13.6 in. (345 mm) brake rotors in the front and 13.8 in. (350 mm) rear rotors.

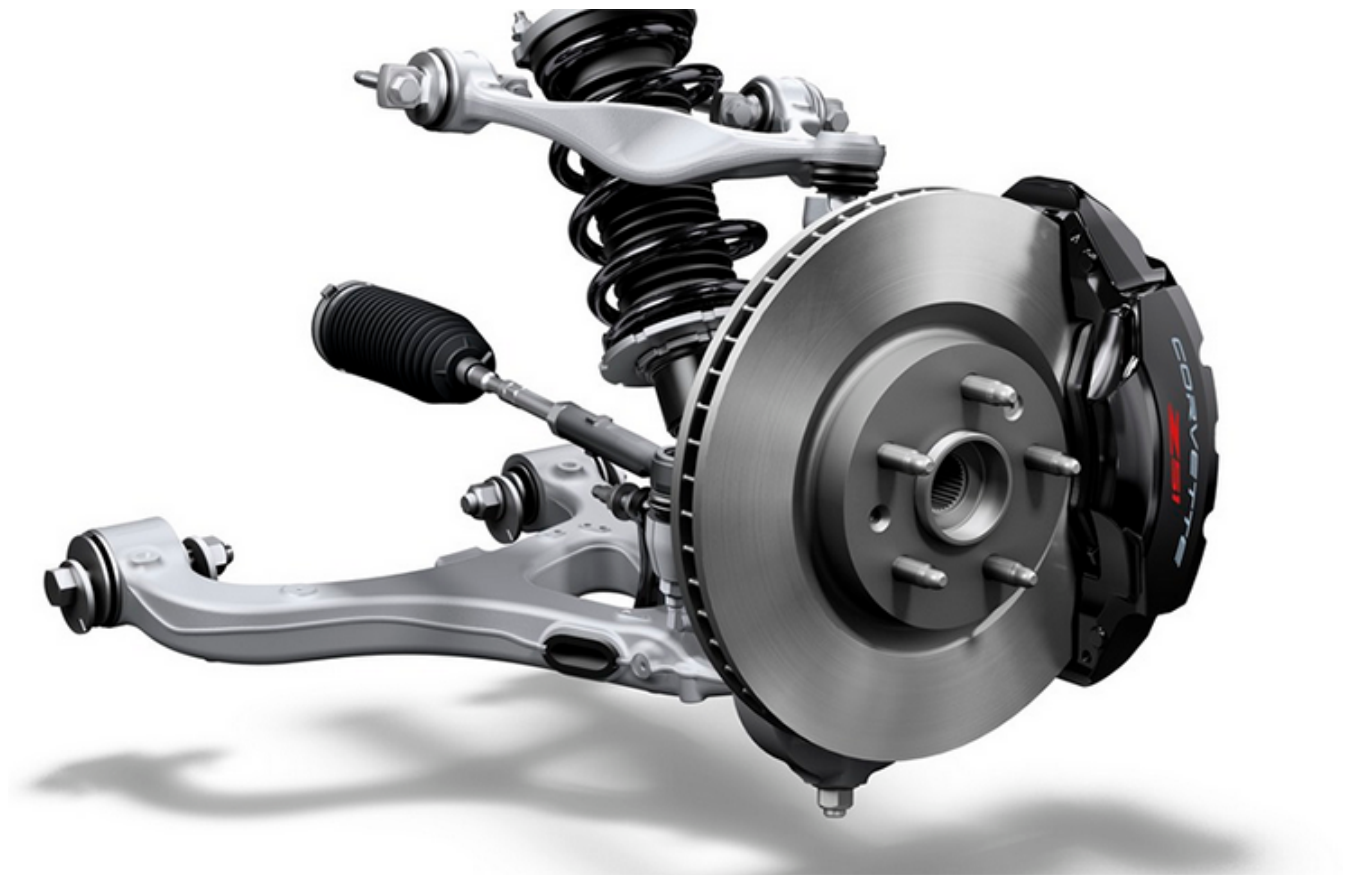

Fig. 10

TIP: The J55 rear brake rotors should not be machined. Removing the coating at the bottom edge of the rotor's braking surface during the machining procedure may lead to surface corrosion.

The J55 system calipers have brake bleeders on the top and bottom of the calipers. The bottom bleeder is to help with draining the brake fluid from the calipers, which is helpful when flushing the brake system after a track event. Pressure bleeding and manual bleeding are the only recommended procedures for flushing and bleeding the brake fluid. Never use vacuum bleeding on 2020 Stingray brake system.

TIP: Copper paste also is required to be applied to the brake pad abutments for both brake systems to reduce brake noise.

Both brake systems use DOT 4 brake fluid. Prior to driving at a track event, the DOT 4 fluid must be flushed out and replaced with a higher boiling temperature brake fluid. After the track event, the brake fluid should be changed back to DOT 4 fluid for street driving.

Critical Brake System Service Step

When servicing vehicles with the Electromechanical Brake Booster, including brake pads or rotor replacements, the battery must be disconnected to prevent the brake master cylinder from pressurizing the hydraulic system during its automated self-diagnostic tests that can possibly occur when a door is opened or the key fob is activated. Failure to follow this precaution may cause personal injury. A "Brake System Failure, 62 mph Top Speed" (or 100 km/h) message will be displayed on the DIC if the battery is not disconnected prior to brake service. (Fig. 11)

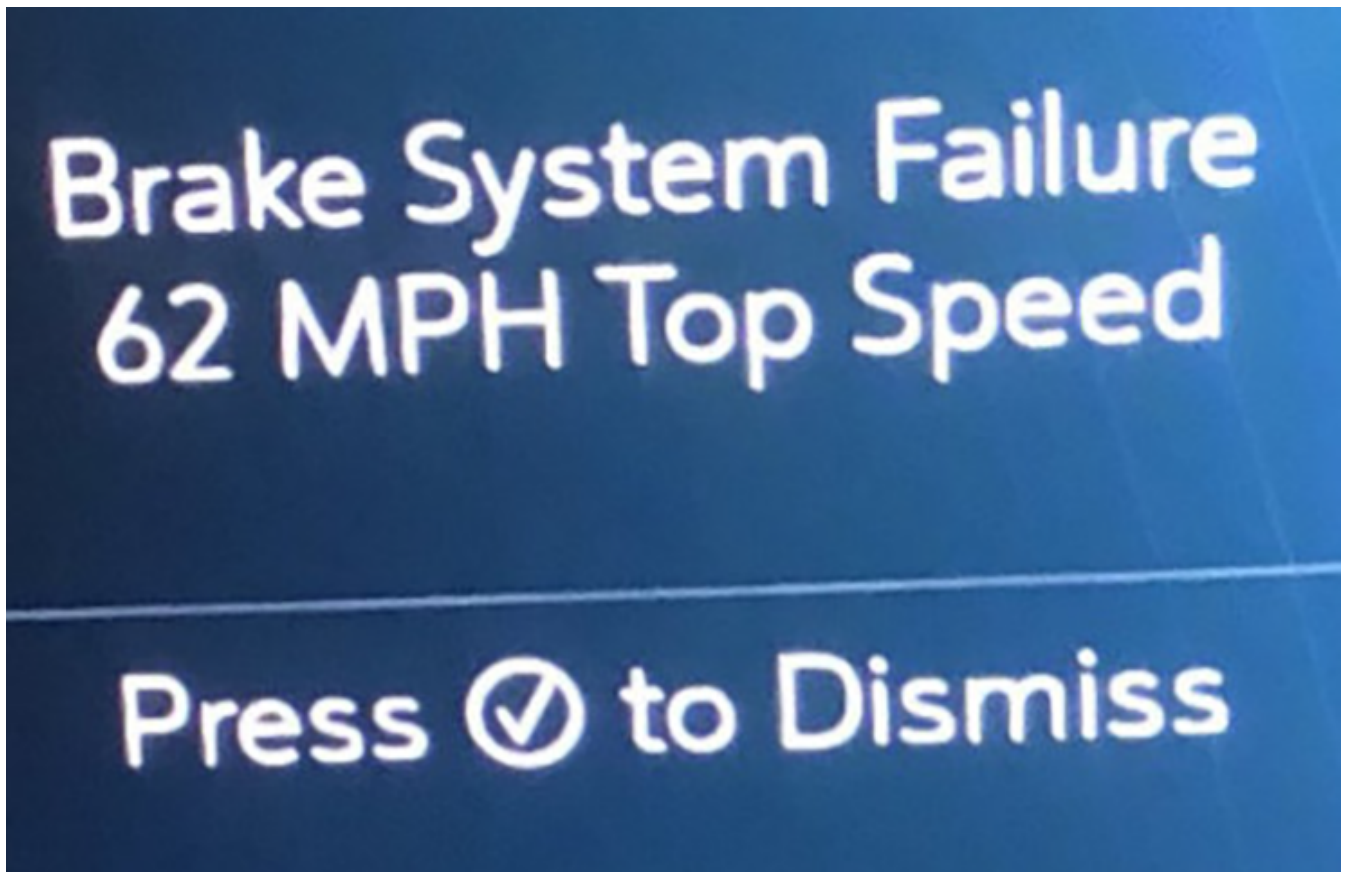

Fig. 11

If the battery is not disconnected and the DIC message appears, it will be necessary to perform a hydraulic system test. The test procedure will not be covered under warranty for failing to disconnect the battery.

Instrument Cluster and Infotainment

In the driver-centered cockpit (Fig. 12) of the Corvette Stingray, the standard instrument panel includes an array of customizable gauges and a multi-color

Head-Up Display.



Fig. 12

The steering wheel controls operate the infotainment system, the instrument panel and DIC, cruise control, and Z-Mode.

The Corvette Stingray also continues to offer a Performance Data Recorder that displays and records video, audio, and vehicle data. The data is stored on a secure digital (SD) memory card. The system is operated through the

infotainment screen.

In Track Mode, the Performance Data Recorder overlays the maximum level of data onto a drive video, including vehicle speed, engine speed, turn signal indicators, high beam indicators, and transmission gear displays. In addition, the lateral and longitudinal G-Forces are displayed as well as the active handling active indicator if active.

Lifting the Vehicle

The spark plugs/wires, ignition coils, A/C compressor, alternator, accessory drive belt and tensioner, and fuel tanks can all be removed from under the vehicle without removing the engine.

TIP: Before lifting the Corvette Stingray, it may be necessary to put the vehicle on gradual incline ramps to allow the lift arms to fit under the vehicle.

Install the J-43625 Lift Pad Adapters into the front and rear frame rail slots and center the hoist pads under the adapters. (Fig. 13)

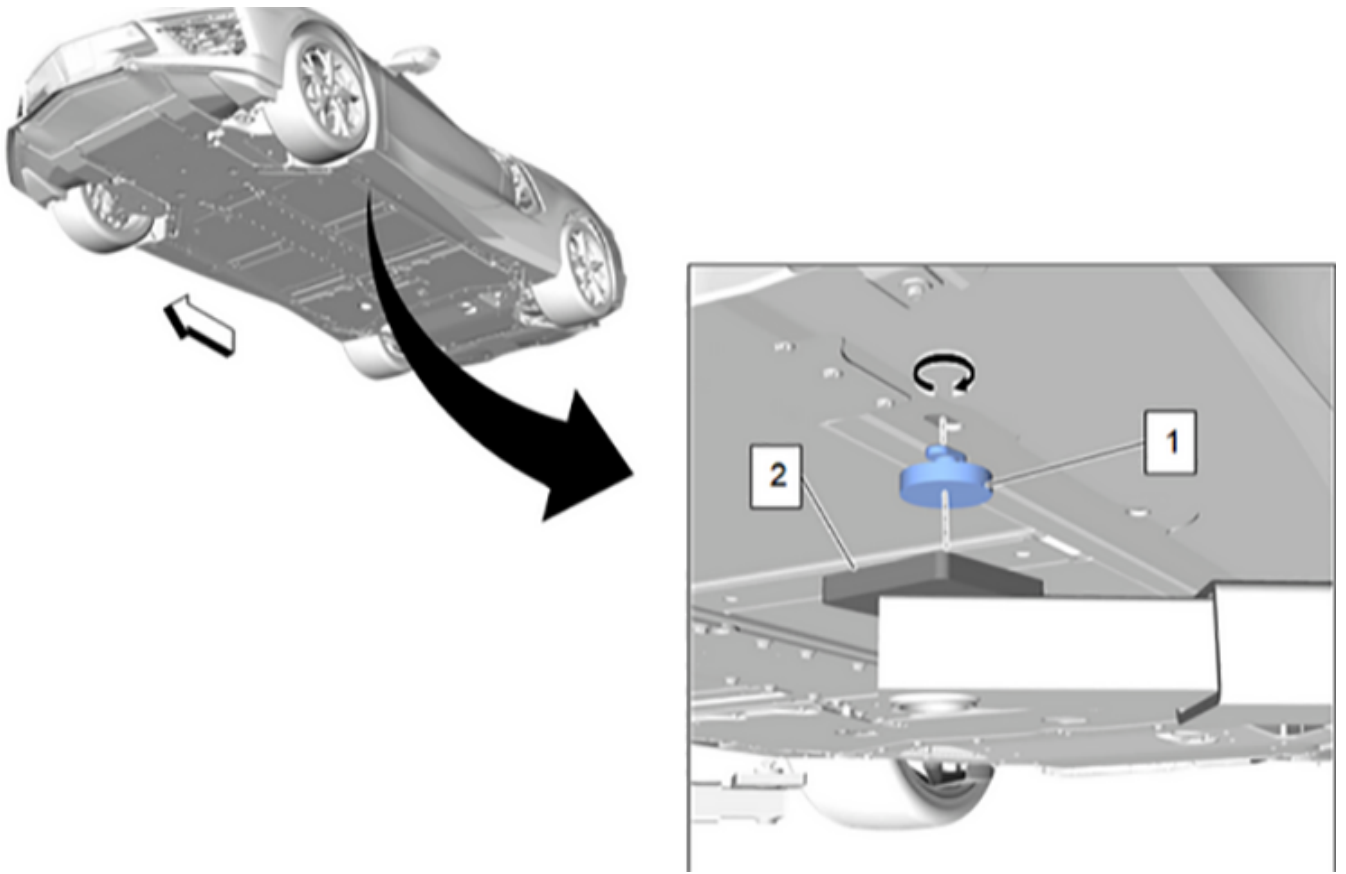

Fig. 13

If the rear cradle shear plate is to be removed, position the hoist pads to allow removal of the mounting bolts. An external Torx socket is required to remove the 36 fasteners that retain the aluminum plate. (Fig. 14) When reinstalling the shear panel, finger start all of the fasteners so they do not get cross threaded into the rear cradle.

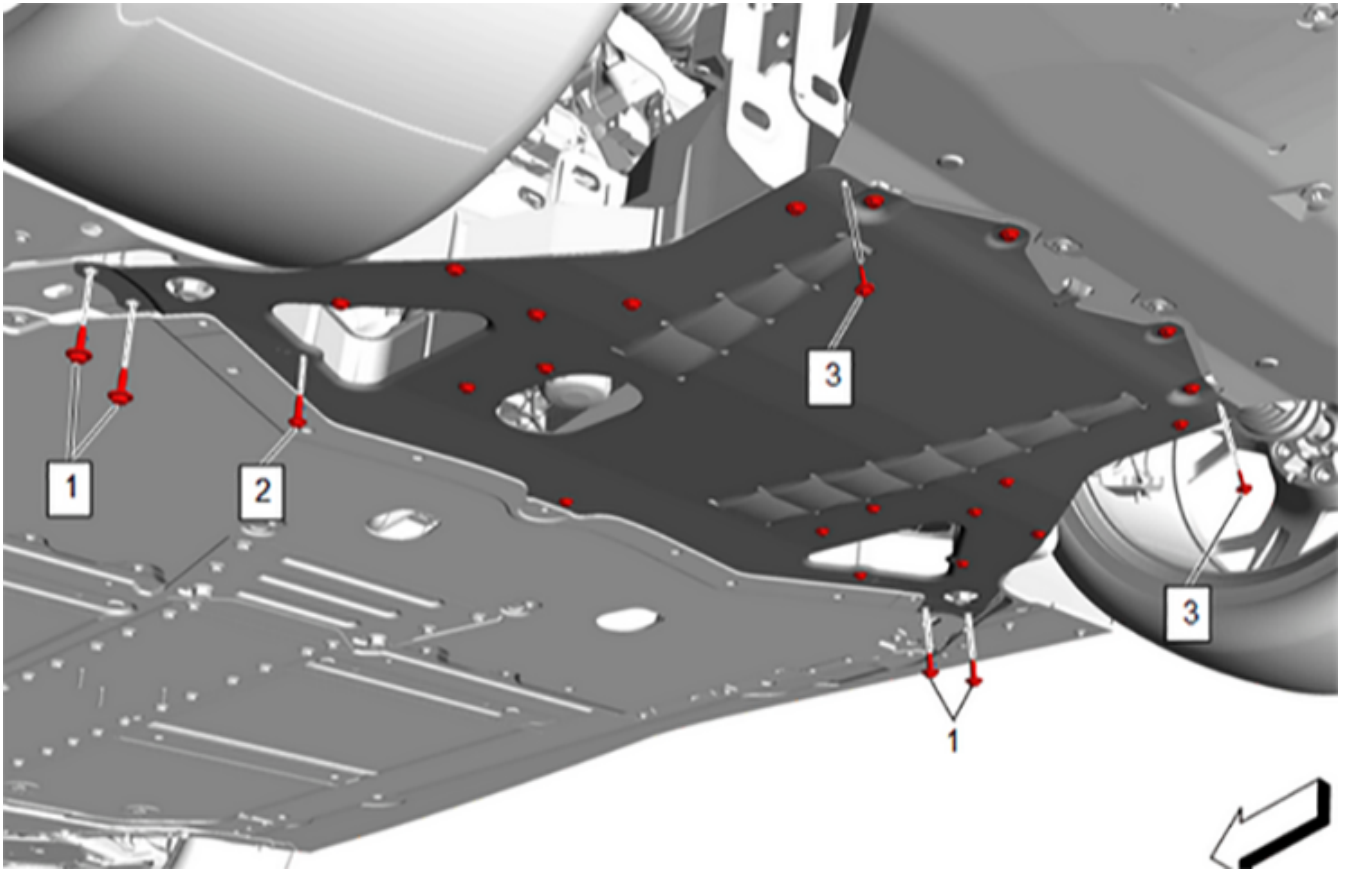

Fig. 14

Special Tools

Part Number

CH-45400-100

CH-47960-15

Description

Strut Compressor Adapter

Alignment Adapter Mounting Pins

DT-52089	Wiring Harness Connector Remover
DT-52388	Manual Park Release Wrench
DT-52660	Transmission Support/Service Fixture
DT-52724	Input Seal Installer
DT-52725	Axle Seal Installer (L & R)
DT-52796	Guide Pins, Control Module Installation
EN-52055-200	Support Mount, Transmission (lift table)
J-44748	Input Shaft Seal Remover
EN-51007-100	Engine Support Fixture Adapter
EN-52499	Engine Support Bolts
EN-52751	Flywheel Holding Tool

For much more information on the all-new 2020 Corvette, refer to Bulletin #20-NA-061.

– *Thanks to Jeff Strausser and Matt Bunting*

Online URL:

<https://www.corvetteactioncenter.com/tech/knowledgebase/article/2020-corvette-gm-techlink-all-new-c8-the-2020-corvette-stingray-makes-a-mid-engine-move-1411.html>