

1973 Corvette: Service Bulletin: Rear Window Water Leak

Subject: Rear Window Water Leak
Model and Year: 1973 Corvette Coupe
Source: Chevrolet Dealer Service Technical Bulletin
Bulletin No: 73-T-75
Section: I
Date: Jan. 2, 1974

TO: ALL CHEVROLET DEALERS

1973 Corvette Coupes may experience water entry around the bottom of the rear window. The plastic window frame may not retain the glass in its proper position, thus allowing the glass to slide down and break the butyl seal.

In 1974, rubber spacers (P/N 4871330) are used to positively locate the window glass in the vertical position.

For service, should the above condition be encountered, it can be corrected by installing three rubber spacers (P/N 4871330) as outlined in the following procedure.

Chevrolet Motor Division
General Motors Corporation

SERVICE PROCEDURE

Rear Window Removal

1. Place protective coverings around area where glass is being removed.

2. Remove six screws and remove rear window frame. If necessary, remove quarter trim.
3. Use "Butyl Glass Sealant Removal Tool, J-24402" to carefully cut adhesive material around entire perimeter of window. Remove glass.
4. If original glass is to be reinstalled, place it on a protected bench or holding fixture and remove old material using a razor blade or sharp scraper. Any remaining traces of adhesive material can be removed from the glass with denatured alcohol or weatherstrip release agent.
5. Using a sharp scraper, remove most of the old adhesive material from the window opening flange around the entire opening. remove remaining traces of adhesive material with denatured alcohol or weatherstrip release agent. Do not use lacquer thinner, as it will damage painted surfaces!

Special Instructions for Use of Urethane Adhesive Caulk Kit P/N 963100

1. Disregard instructions in kit as they apply to windshield installation only.
2. Discard butyl strip provided in kit.
3. CAUTION: Use extreme care in handling the urethane caulking material as cleanup is very difficult. rubber gloves are recommended.

Rear Window Installation

1. Apply a strip of masking tape around outer surface of glass 1/2 inch inboard of outer edge (figure 1). Removal of tape after glass installation will aid in cleanup and give a smooth, even edge of adhesive material.
2. Apply masking tape around entire edge of painted body surface to prevent adhesive material or primer from contacting exposed body surfaces.
3. Apply primer (provided in kit) around perimeter of outside surface and edge of window glass. Allow primer to dry approximately 10 minutes.

4. Apply primer liberally to pinchweld flange. Allow to dry approximately 10 minutes.

CAUTION : Use extreme care to avoid spilling primer solution on trim or painted surfaces. Wipe any spills immediately, as primer will etch trim or painted surfaces on prolonged contact.

5. Install three rubber spacers (P/N 4871330) as shown in figure 2. Cement in place with the urethane caulking material.
6. With the aid of a helper, lift and center the glass into the window opening, placing it on the rubber spacers. It will be necessary to use suction cups to position the glass in the opening.
7. After glass is centered, apply two strips of masking tape over the glass and window opening, one on each side, to aid in alignment during final installation.
8. Cut making tape as close to window opening as possible.
9. (*Corvette Action Center Note: Step 9 is missing from our copy of the service bulletin...*)
10. Apply smooth continuous bead of adhesive material around entire outside perimeter of glass. Material should be 1/8" to 3/16" in diameter (refer to figure 1).

NOTE: Due to fast curing characteristics of adhesive material, glass installation should be completed within 15 minutes from start of application.

11. With the aid of a helper and suction cups, place bottom edge of glass on rubber spacers, being careful not to allow adhesive to come in contact with pinchweld flange.
12. Align glass with the aid of the masking tape strips previously applied for that purpose. Press glass firmly to "wet-out" and "set" adhesive material. Smooth out adhesive along bottom of window and remove any excess. Paddle in additional material to bring up to level of body surface if necessary.
13. Replace rear window frame and quarter trim.
14. Water test using soft spray. use warm or hot water if available. if

water leak is encountered, work in additional material at leak point.

15. Carefully remove masking tape from perimeter of window and body opening. Pull tape toward center of glass to give a clean-cut edge to adhesive material.
16. Perform any additional cleanup as required.
17. Vehicle must remain in normal room temperature (72°F) for six hours to complete proper cure of adhesive caulking material.

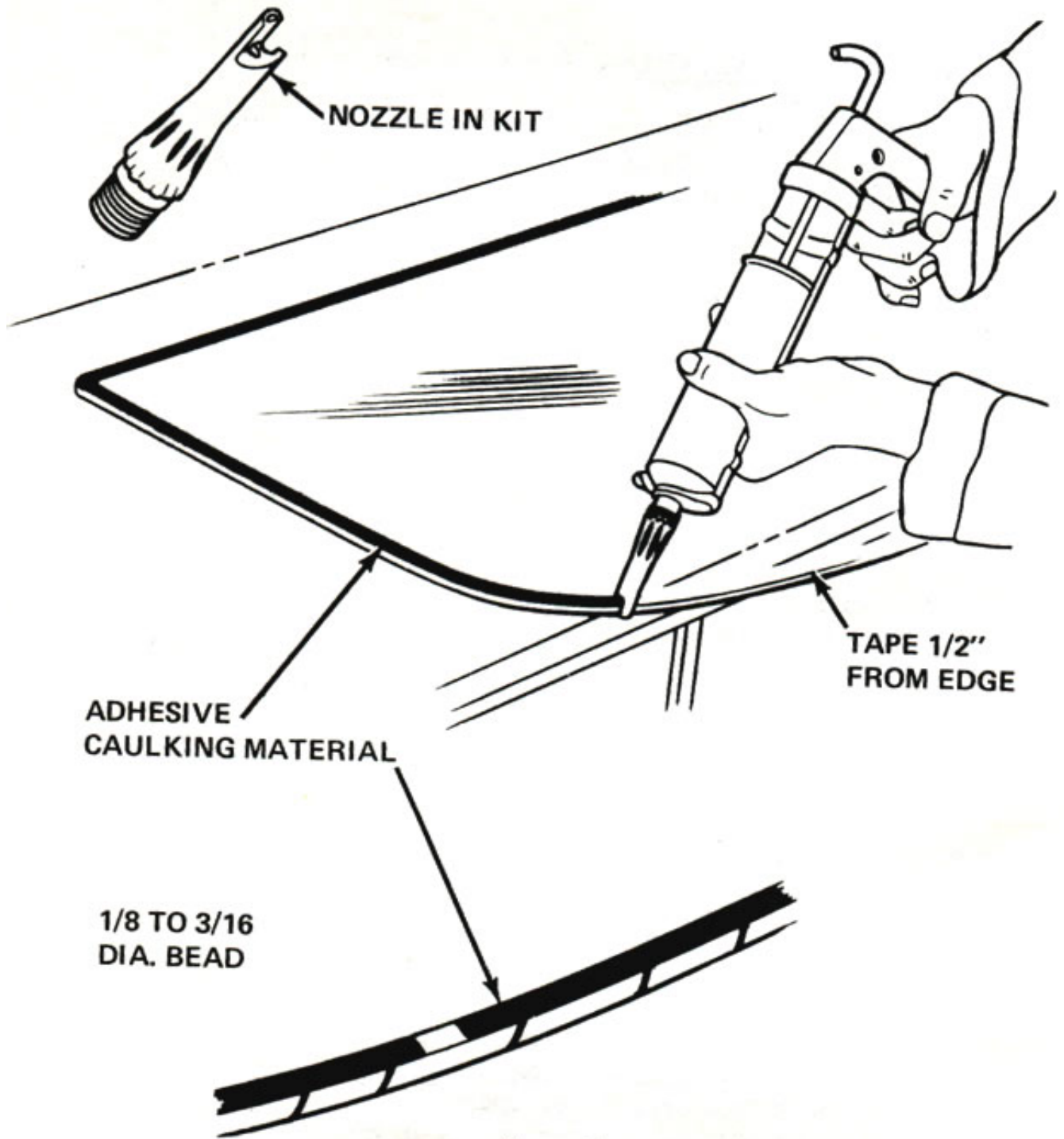

Figure 1

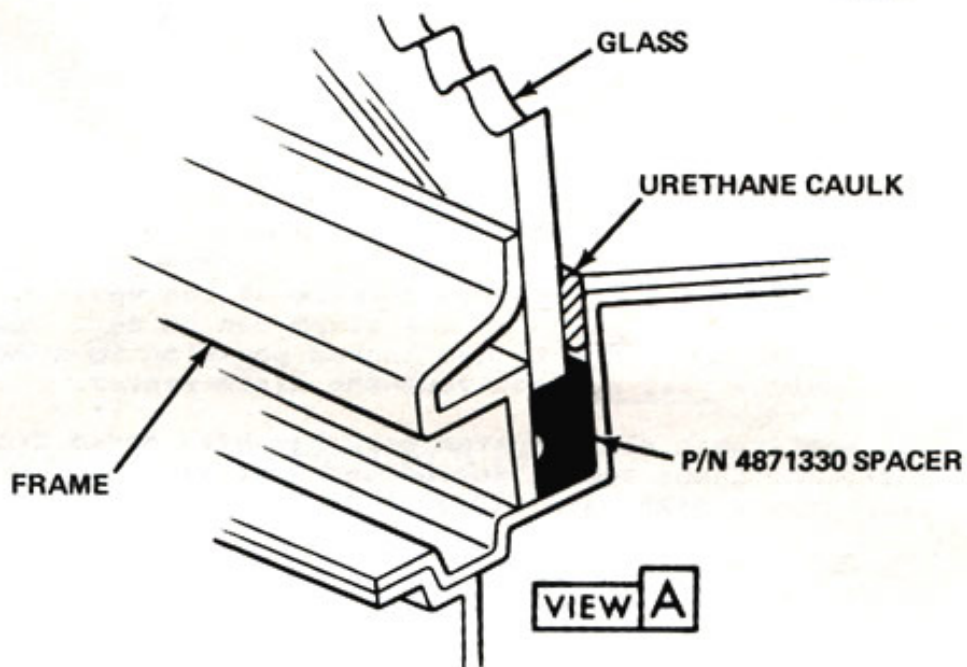
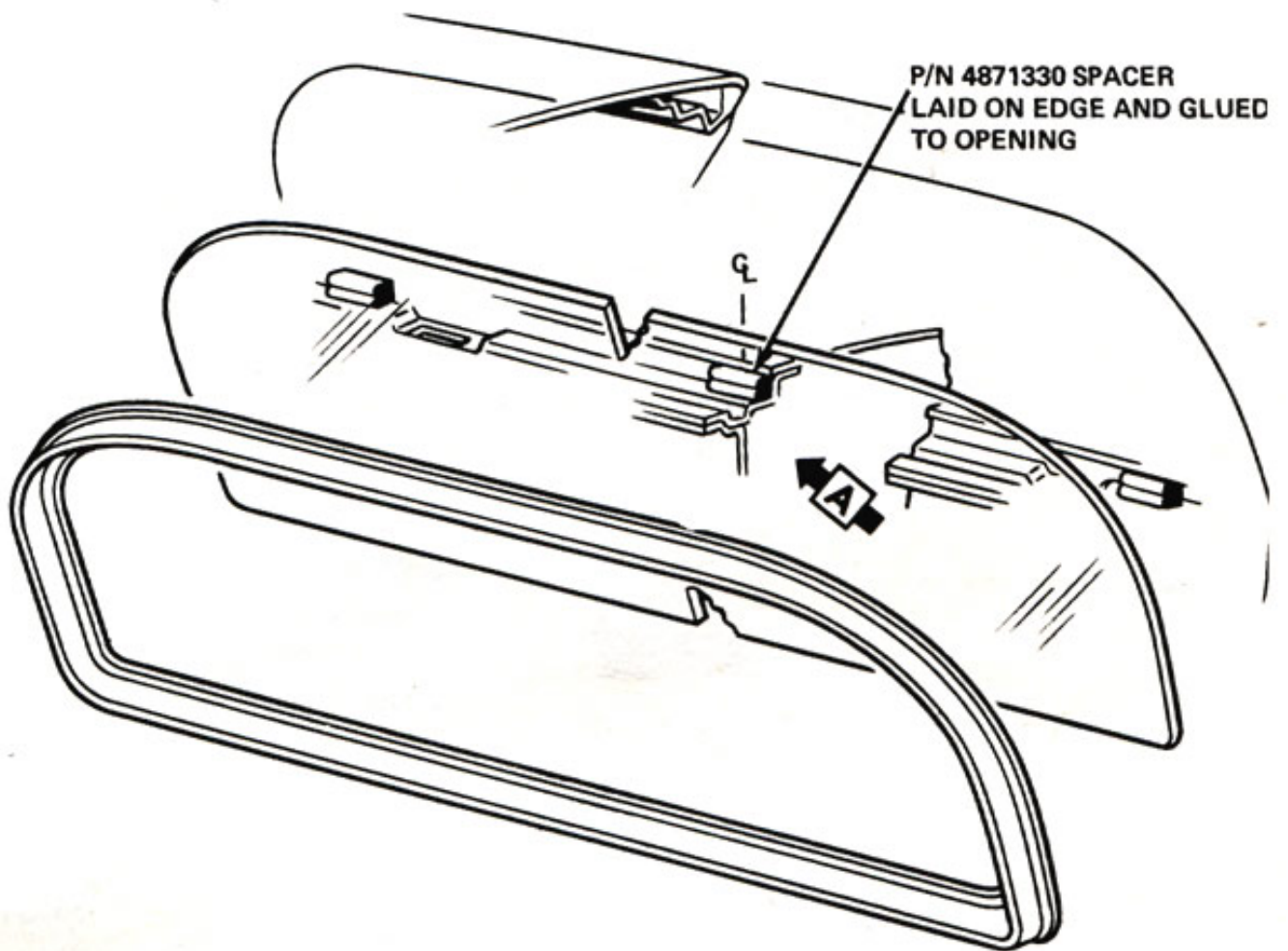

Figure 2

Online URL:

<https://www.corvetteactioncenter.com/tech/knowledgebase/article/1973-corvette-service-bulletin-rear-window-water-leak-1117.html>