



Program Bulletin



CUSTOMER SATISFACTION PROGRAM

SUBJECT: Low Rear Differential Fluid Level

MODELS: 2014 Chevrolet Corvette

.....
THIS PROGRAM IS IN EFFECT UNTIL NOVEMBER 30, 2015.
.....

CONDITION

The rear differential assembly in **certain** 2014 model year Chevrolet Corvette vehicles may have been shipped from the supplier with insufficient fluid. Operating the vehicle without sufficient fluid in the rear differential assembly could produce a loud whine and/or gear or bearing noise.

CORRECTION

Dealers are to inspect the rear differential fluid level and add fluid, if necessary. If fluid is required, dealers are to also road-test the vehicle and listen for rear axle noise. If a whine, gear or bearing noise is present, dealers are to replace the rear differential assembly.

VEHICLES INVOLVED

All involved vehicles are identified by Vehicle Identification Number on the Investigate Vehicle History screen in GM Global Warranty Management system. Dealership service personnel should always check this site to confirm vehicle involvement prior to beginning any required inspections and/or repairs. It is important to routinely use this tool to verify eligibility because not all similar vehicles may be involved regardless of description or option content.

For dealers with involved vehicles, a listing with involved vehicles containing the complete vehicle identification number, customer name, and address information has been prepared and will be provided to US and Canadian dealers through the GM GlobalConnect Recall Reports, or sent directly to export dealers. Dealers will not have a report available if they have no involved vehicles currently assigned.

The listing may contain customer names and addresses obtained from Motor Vehicle Registration Records. The use of such motor vehicle registration data for any purpose other than follow-up necessary to complete this program is a violation of law in several

states/provinces/countries. Accordingly, you are urged to limit the use of this report to the follow-up necessary to complete this program.

PART INFORMATION

Differential fluid, if required, is to be obtained from General Motors Customer Care and Aftersales (GMCC&A). Please refer to your "involved vehicles listing" before ordering parts. Normal orders should be placed on a DRO = Daily Replenishment Order. In an emergency situation, parts should be ordered on a CSO = Customer Special Order.

In the rare event that a rear differential requires replacement, orders will be processed through the PQC with a PQC case prior to release by calling 866-654-7654. Please reference PIP 5142 for exchange program instructions.

Part Number	Description	Quantity/Vehicle
88862624 – US 88862625 - CN	LUBRICANT, DIFFERENTIAL	Up to 3 quarts/litres (Submit as Net Item)

SERVICE PROCEDURE

1. Raise and support vehicle. Refer to *Lifting and Jacking the Vehicle* in SI.

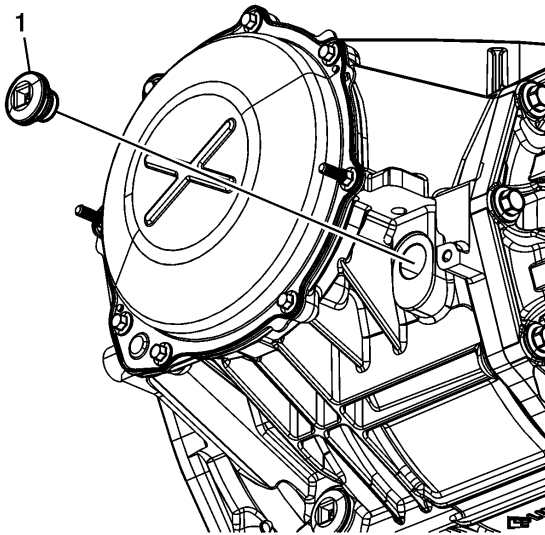

3404597

2. Check the rear axle fluid level. Refer to *Rear Axle Lubricant Level Inspection* in SI.
 - If adding rear axle fluid is NOT required, no further action is required. Lower the vehicle. Refer to *Lifting and Jacking the Vehicle* in SI.
 - If adding rear axle fluid is required, add the recommended amount of fluid to the rear axle. Proceed to step 3.
3. Take the vehicle on a 10 minute road test to determine if there is a whine, gear or bearing noise.
 - If rear axle noise is NOT present, no further action is required.
 - If rear axle noise is present, contact the PQC for additional instructions.

COURTESY TRANSPORTATION – For US and Canada

The General Motors Courtesy Transportation program is intended to minimize customer inconvenience when a vehicle requires a repair that is covered by the New Vehicle Limited Warranties. The availability of courtesy transportation to customers whose vehicles are within the warranty coverage period and involved in a product program is very important in maintaining customer satisfaction. Dealers are to ensure that these customers understand that shuttle service or some other form of courtesy transportation is available and will be provided at no charge. Dealers should refer to the General Motors Service Policies and Procedures Manual for Courtesy Transportation guidelines.

WARRANTY TRANSACTION INFORMATION

Submit a transaction using the table below. All transactions should be submitted as a ZFAT transaction type, unless noted otherwise.

Labor Code	Description	Labor Time	Net Item
9100238	Inspect Rear Differential Fluid Level – No Further Action Req'd	0.3	N/A
9100239*	Inspect & Add Differential Fluid & Road Test Vehicle	0.7	**

* If the rear differential requires replacement, submit for the inspection, fluid add, and road test under this bulletin using labor code 9100239. Use normal warranty labor code and labor operation time for the replacement of the rear differential.

** Submit the cost of the actual amount of differential fluid used to perform the required repairs, not to exceed \$38.40 USD, \$39.49 CAD, plus applicable Mark-Up.

CUSTOMER NOTIFICATION – For US and Canada

General Motors will notify customers of this program on their vehicle (see copy of customer letter included with this bulletin).

CUSTOMER NOTIFICATION – For Export

Letters will be sent to known owners of record located within areas covered by the US National Traffic and Motor Vehicle Safety Act. For owners outside these areas, dealers should notify customers using the attached sample letter.

DEALER PROGRAM RESPONSIBILITY

All unsold new vehicles in dealers' possession and subject to this program must be held and inspected/repaired per the service procedure of this program bulletin before customers take possession of these vehicles.

Dealers are to service all vehicles subject to this program at no charge to customers, regardless of mileage, age of vehicle, or ownership, through November 30, 2015.

Customers who have recently purchased vehicles sold from your vehicle inventory, and for which there is no customer information indicated on the involved vehicle listing, are to be contacted by the dealer. Arrangements are to be made to make the required correction according to the instructions contained in this bulletin. A copy of the customer letter is provided in this bulletin for your use in contacting customers. Program follow-up cards should not be used for this purpose, since the customer may not as yet have received the notification letter.

In summary, whenever a vehicle subject to this program enters your vehicle inventory, or is in your facility for service through November 30, 2015, you must take the steps necessary to be sure the program correction has been made before selling or releasing the vehicle.



November 2013

Dear General Motors Customer:

We have learned that the rear differential assembly in your 2014 model year Chevrolet Corvette may have been shipped from the supplier with insufficient fluid. Operating the vehicle without sufficient fluid in the rear differential assembly could produce a loud whine and/or gear or bearing noise.

Your satisfaction with your Chevrolet Corvette is very important to us, so we are announcing a program to address this condition.

What We Will Do: Your GM dealer will inspect the rear differential fluid level and add fluid, if necessary. If fluid is required, your dealer will also road-test the vehicle to listen for rear axle noise. If a whine, gear or bearing noise is present, your dealer will replace the rear differential assembly. This service will be performed for you at **no charge until November 30, 2015**. After that, any applicable warranty will apply.

What You Should Do: To limit any possible inconvenience, we recommend that you contact your dealer as soon as possible to schedule an appointment for this repair.

If you have any questions or concerns that your dealer is unable to resolve, please contact the appropriate Customer Assistance Center at the number listed below.

Division	Number	Text Telephones (TTY)
Chevrolet	1-800-222-1020	1-800-833-2438
Guam	65-6267-1752	
Puerto Rico – English	1-800-496-9992	
Puerto Rico – Español	1-800-496-9993	
Virgin Islands	1-800-496-9994	

Courtesy Transportation: If your vehicle is within the New Vehicle Limited Warranty, your dealer may provide you with shuttle service or some other form of courtesy transportation while your vehicle is at the dealership for this repair. Please refer to your Owner Manual and your dealer for details on Courtesy Transportation.

We sincerely regret any inconvenience or concern that this situation may cause you. We want you to know that we will do our best, throughout your ownership experience, to ensure that your Chevrolet Corvette provides you many miles of enjoyable driving.

Jim Moloney
General Director,
Customer and Relationship Services